

ZL1 Brake Kit—Front Installation Sheet for Both V6 & V8SS Models

FRONT KIT CONTENTS

Kit BOM	Qty
Front Installation Sheet	1
ZL1 Front LH Rotor	1
ZL1 SPO Front LH Caliper	1
ZL1 SPO Front RH Caliper	1
SPO Front Caliper Pin Kit	2
SPO Front Service Pad Kit	1
ZL1 Front LH Hose	1
ZL1 Front LH Shield	1
ZL1 Front RH Rotor	1
ZL1 Front RH Hose	1
ZL1 Front RH Shield	1
Front LH & RH Caliper to Knuckle Bolts	4
Front & Rear Hose Bolts	2
Front & Rear Hose Washers	4
Chevrolet Performance Badge	1

REMOVAL PROCEDURE

Jack vehicle and remove tire and wheel.

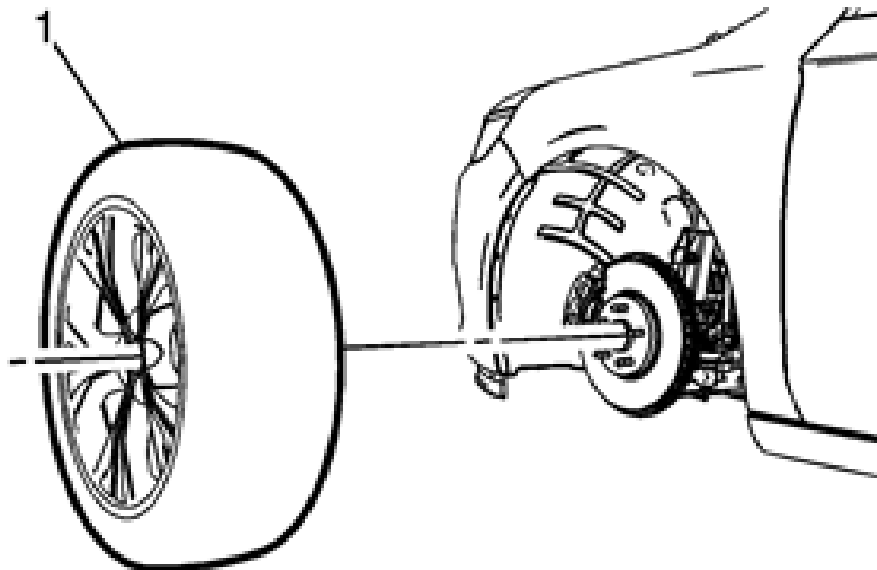

Remove Brake Caliper Hose

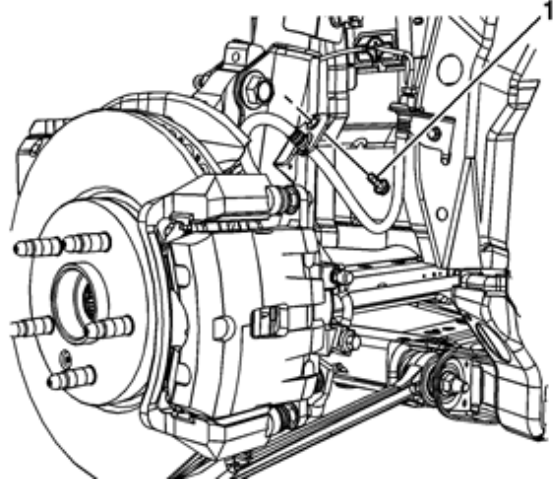
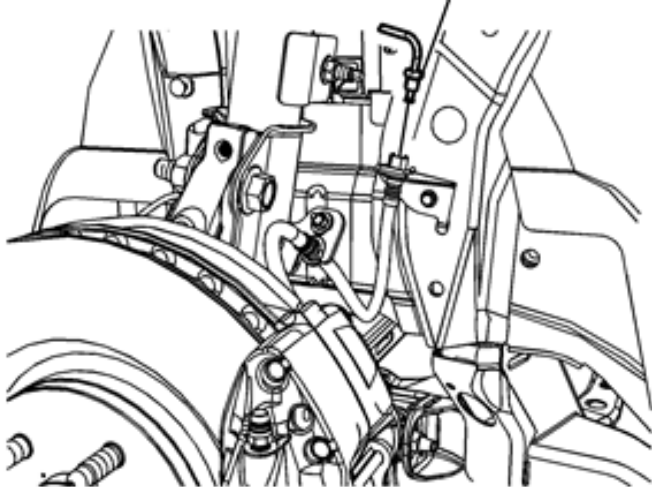

Disconnect the brake pipe fitting (1) from the brake hose.

Remove the brake hose bracket bolt (1) from the strut assembly.

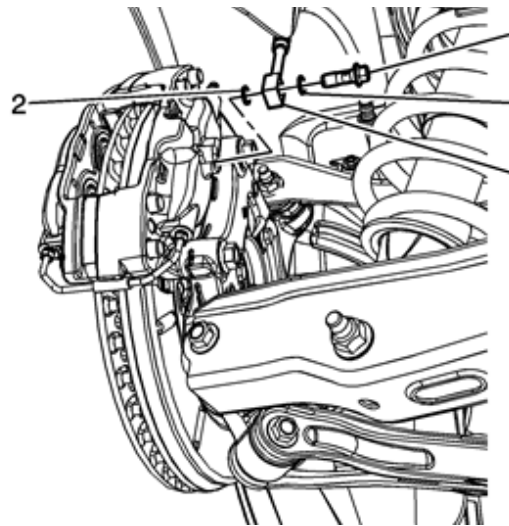
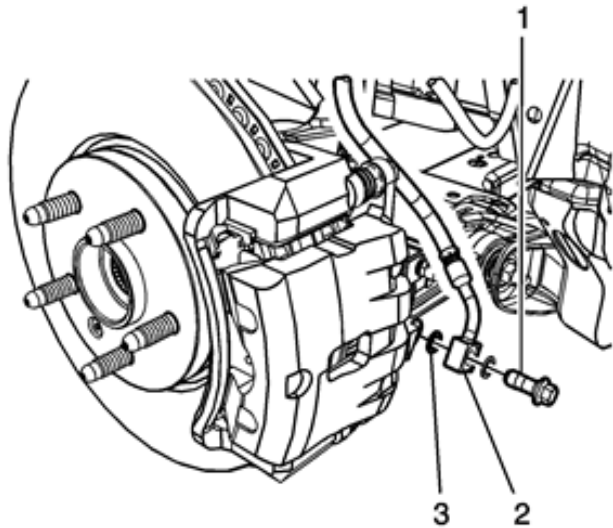

Disconnect hose bolt from caliper, discard washers.
Remove caliper assembly from knuckle.

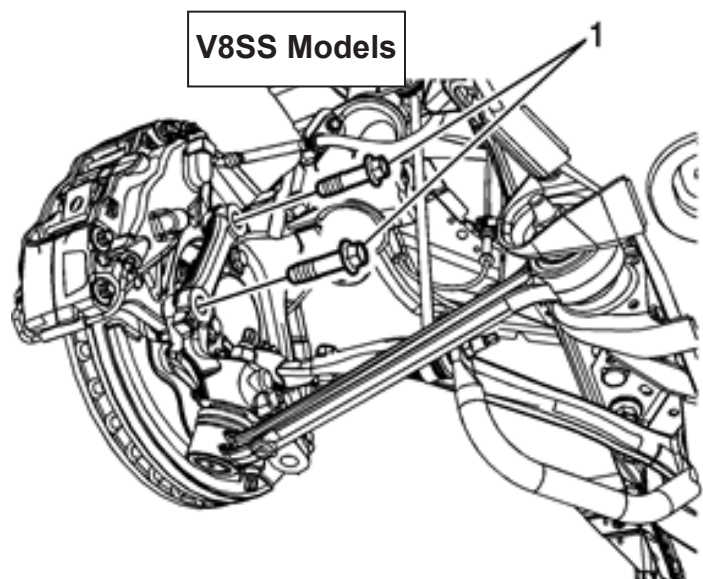
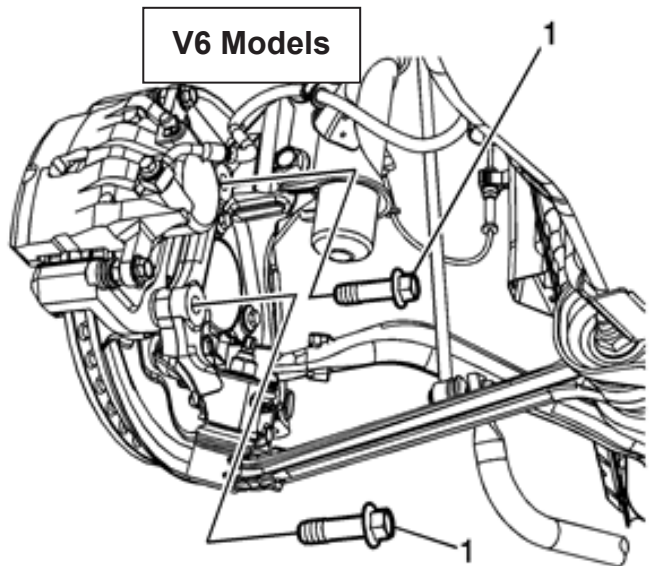

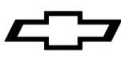

Remove the brake rotor.

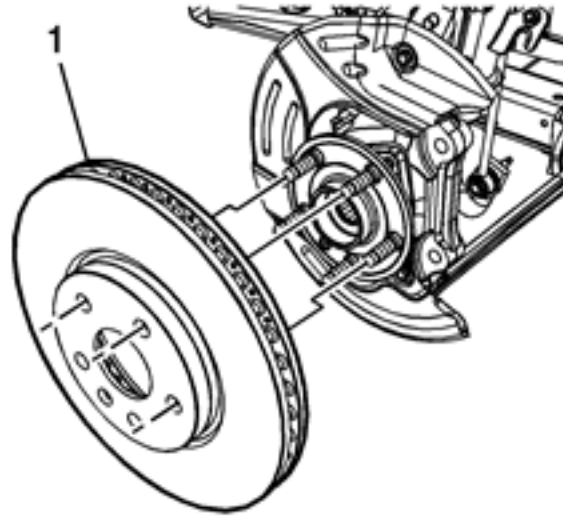
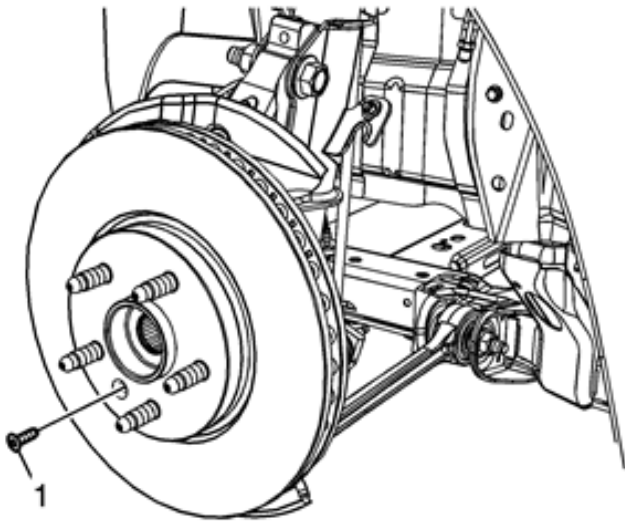

Remove the shield.

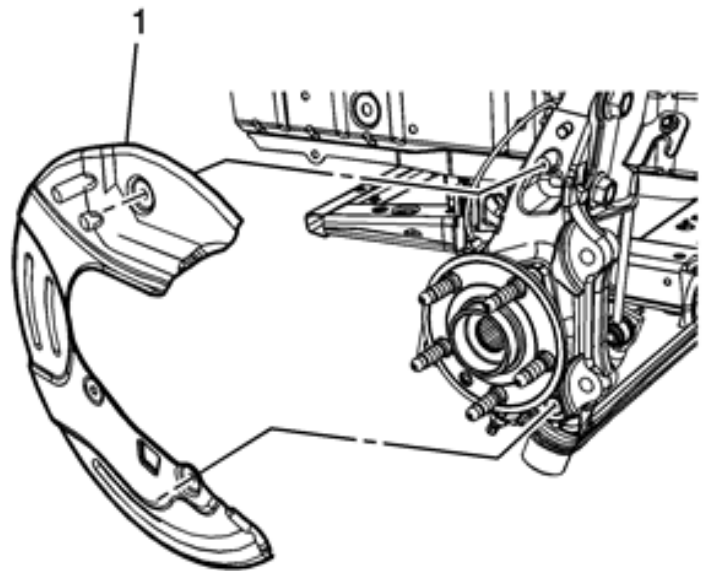
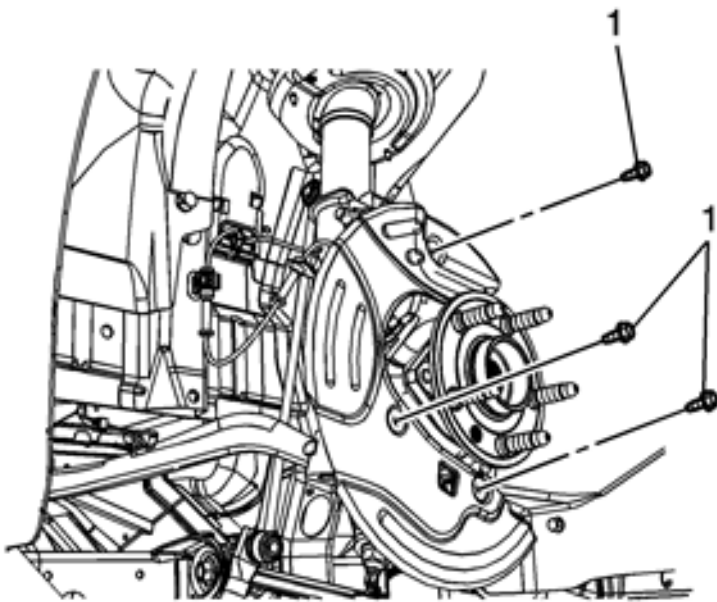

INSTALLATION PROCEDURE

Install ZL Front Shield

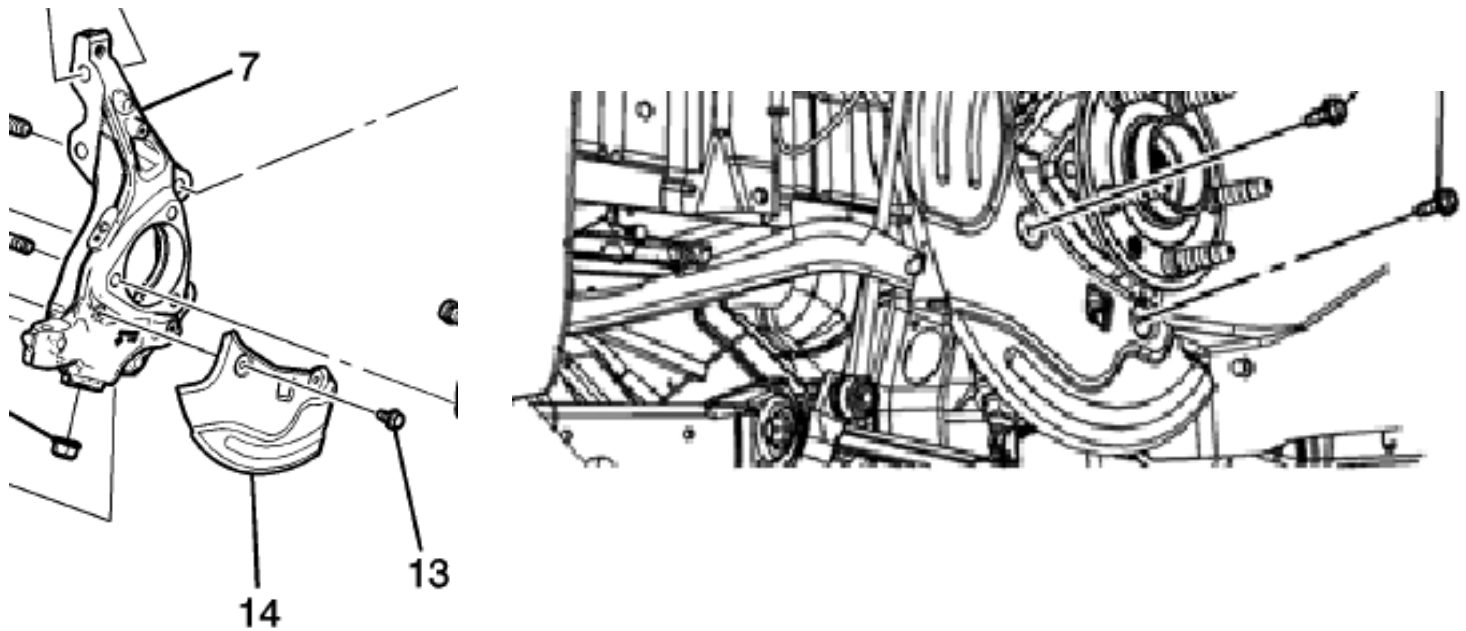

Install the front brake shield bolts (13) and tighten to **9 N·m (80 lb in)**. Use 2 of 3 bolts from the removal.

Install Front Brake Rotors

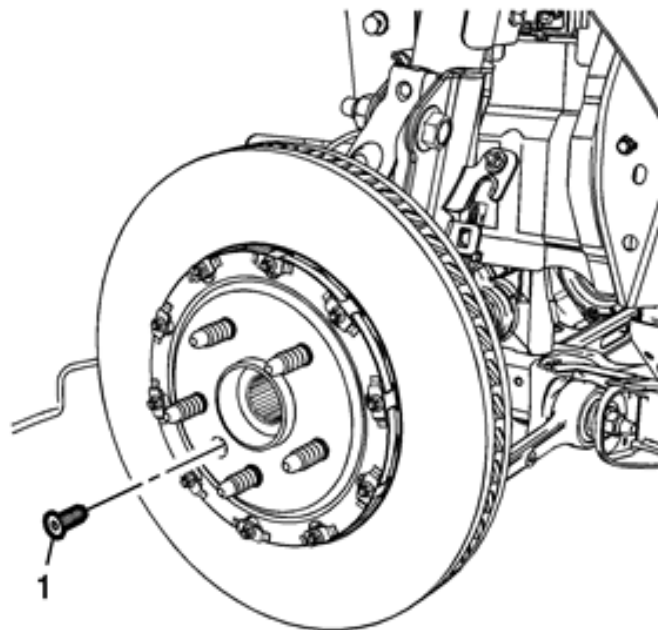

Install the brake rotor screw (1) and tight to **10 N·m (89 lb in)**.
Use screw from removal.

Install ZL1 Brake Caliper

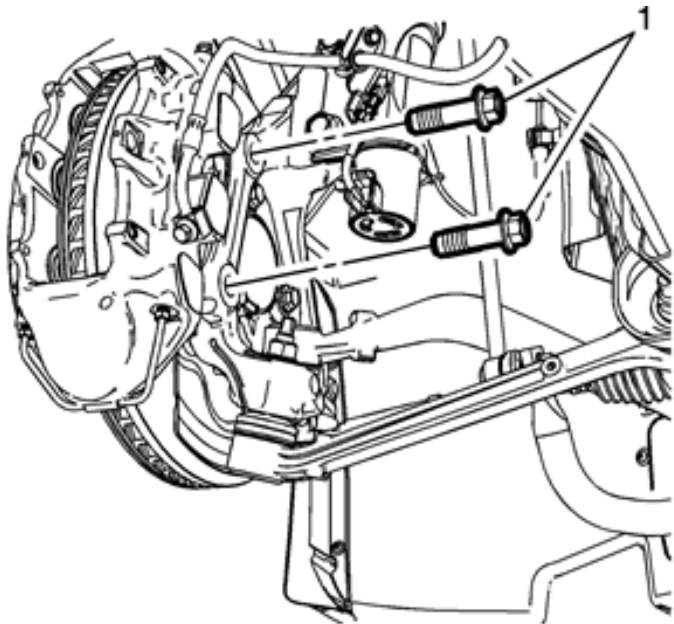

Note: The brake caliper bolts must be replaced any time they are removed.

Install new brake caliper bolts (1) and tighten to **40 N·m (30 lb ft) + 90 degrees**.

Caliper bolts provided in kit contents.

Install ZL1 Caliper Pads and ZL1 Pin Kit

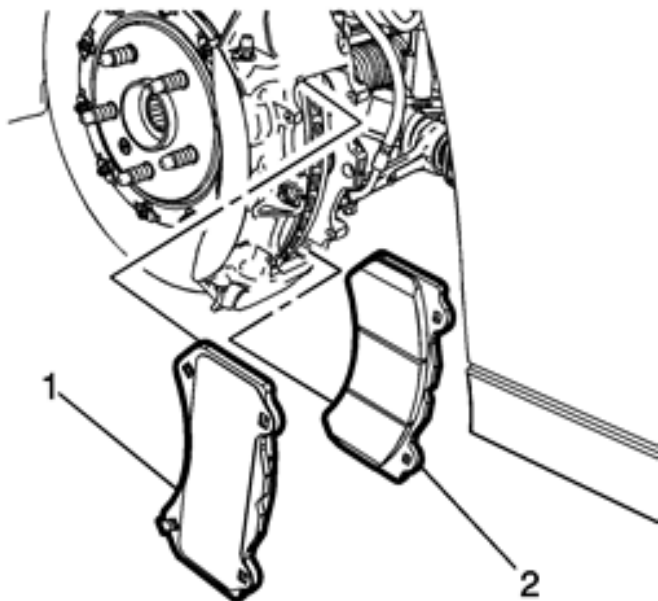

Note: Align the brake pad wear sensor as noted during removal.

Install the outer brake pad (1).

Install the inner brake pad (2).

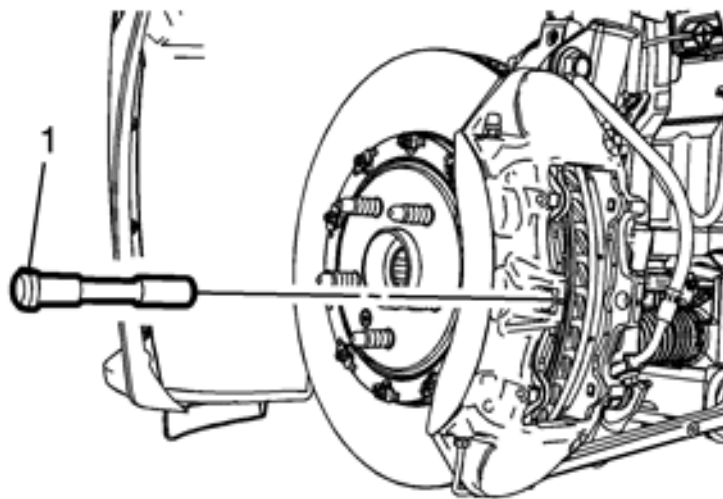

Install the brake caliper guide pin (1).

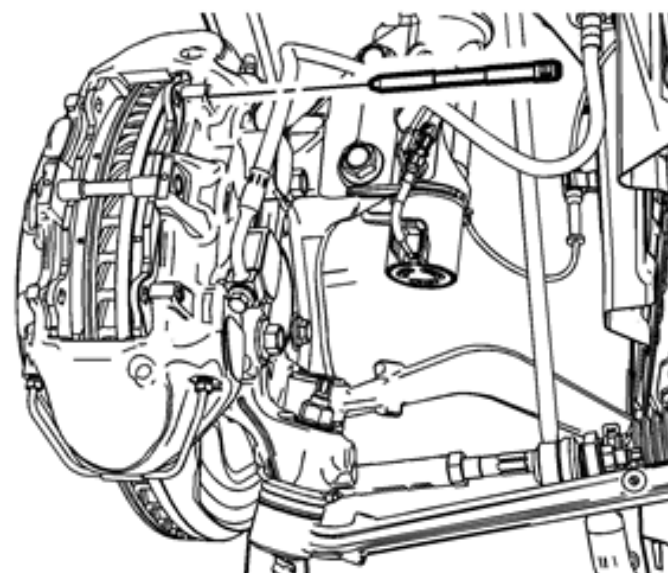
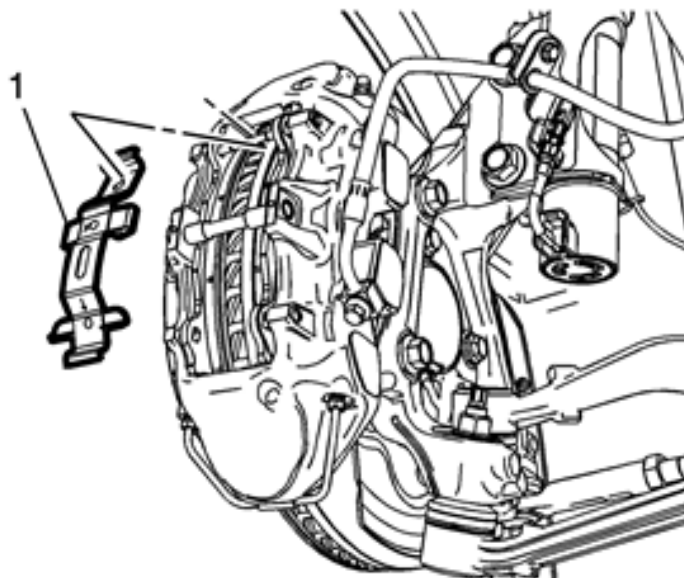

Install the upper brake pad pin (1).

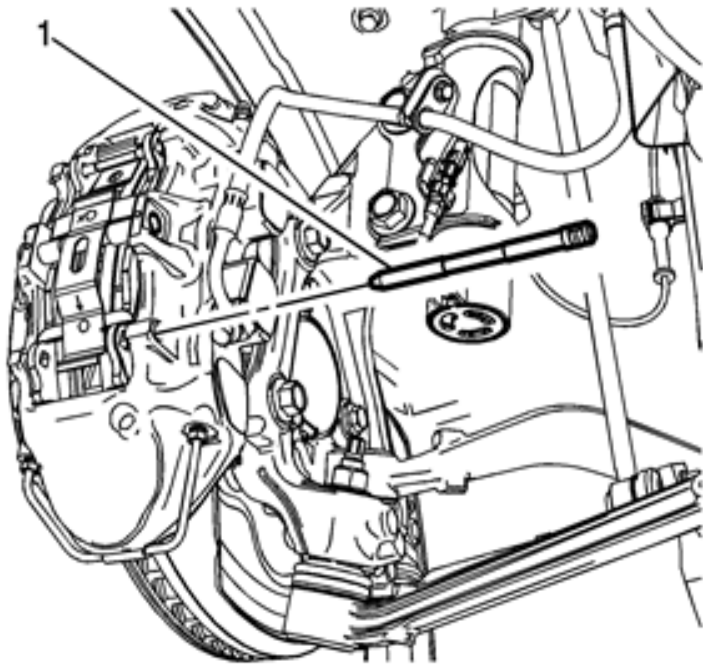

Install the lower brake pad pin (1).

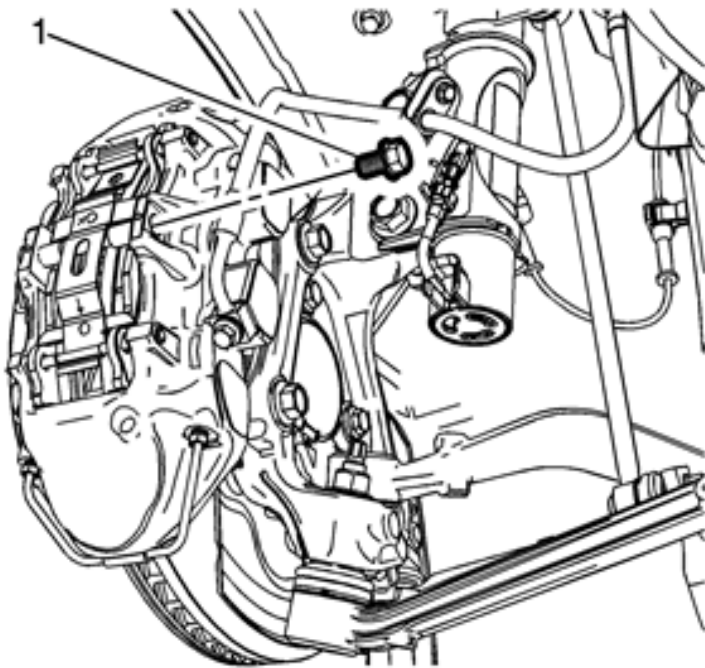

Install the brake caliper guide pin bolt (1) and tighten the bolt to **33 N·m (24 lb ft)**.

Install ZL1 Front Brake Hose

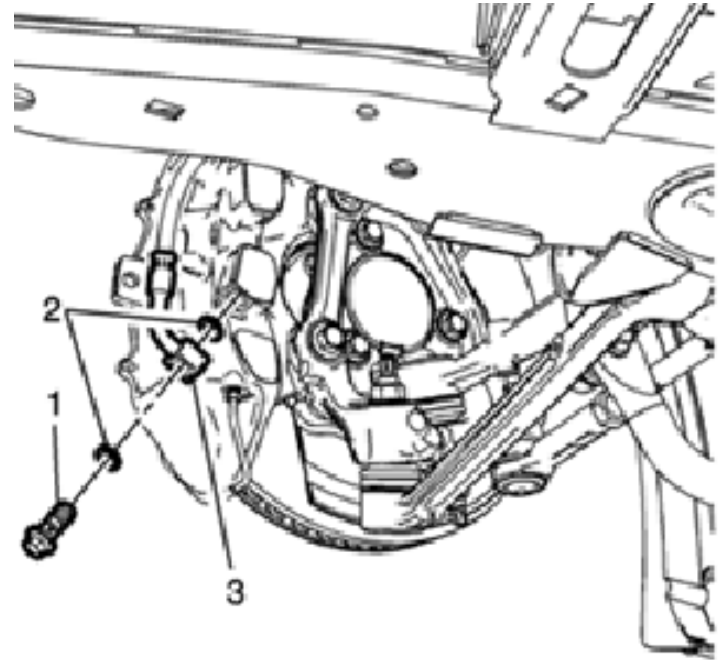

Assemble the brake hose fitting bolt (1) with two new brake hose fitting gaskets (2) to the brake hose (3).

Install the brake hose assembly to the brake caliper and tighten the brake hose fitting bolt to **40 N·m (30 lb ft)**.

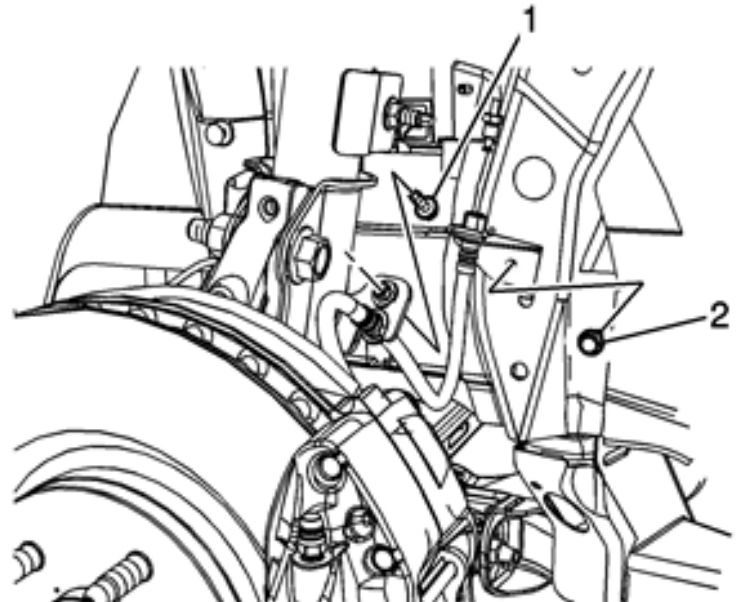

Connect the brake pipe fitting (1) and tighten to **16 N·m (12 lb ft)**.

Bleed the hydraulic brake system.

Install the tire and wheel assembly.

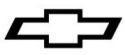

Burnishing

Burnishing the brake pads and brake rotors is necessary in order to ensure that the braking surfaces are properly prepared after service has been performed on the disc brake system.

This procedure should be performed whenever the disc brake rotors have been refinished or replaced, and/or whenever the disc brake pads have been replaced.

1. Select a smooth road with little or no traffic.
2. Accelerate the vehicle to 48 km/h (30 mph).
Note: Use care to avoid overheating the brakes while performing this step.
3. Using moderate to firm pressure, apply the brakes to bring the vehicle to a stop. Do not allow the brakes to lock.
4. Repeat steps 2 and 3 until approximately 20 stops have been completed. Allow sufficient cooling periods between stops in order to properly burnish the brake pads and rotors.

Trousse de frein ZL1 – Fiche de pose avant pour les modèles V6 et V8SS

CONTENU DE LA TROUSSE DE FREIN

Nomenclature de la trousse	Quantité
Fiche de pose avant	1
Disque avant gauche ZL1	1
Étrier avant gauche SPO ZL1	1
Étrier avant droit SPO ZL1	1
Trousse d'axe d'étrier avant SPO	2
Trousse de plaquette de rechange avant SPO	1
Flexible avant gauche ZL1	1
Tôle de protection avant gauche ZL1	1
Disque avant droit ZL1	1
Flexible avant droit ZL1	1
Tôle de protection avant droite ZL1	1
Boulons, étriers avant gauche et droit aux joints d'articulation	4
Boulons de flexible avant et arrière	2
Rondelles de flexible avant et arrière	4
Emblème Chevrolet Performance	1

PROCÉDURE DE DÉPOSE

Lever le véhicule et déposer l'ensemble roue et pneu.

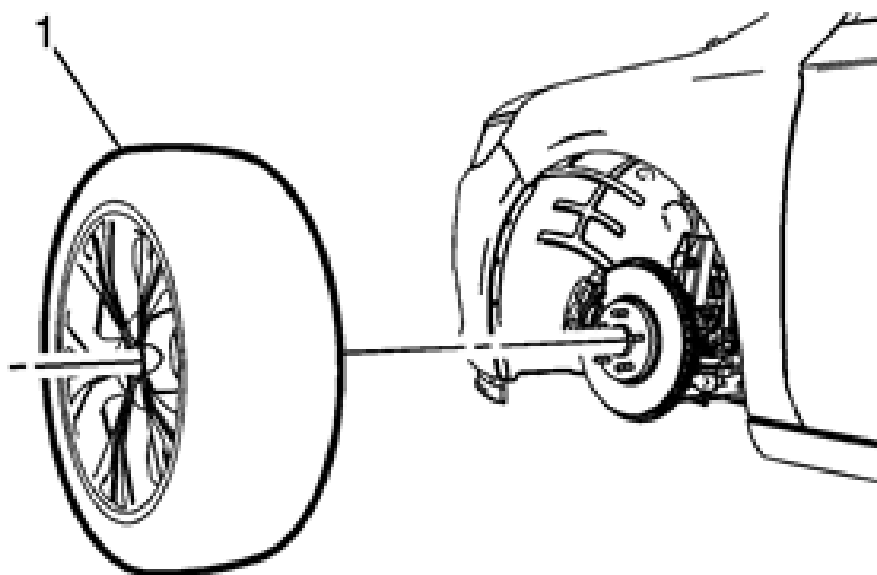

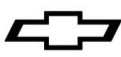

Déposer le flexible d'étrier de frein

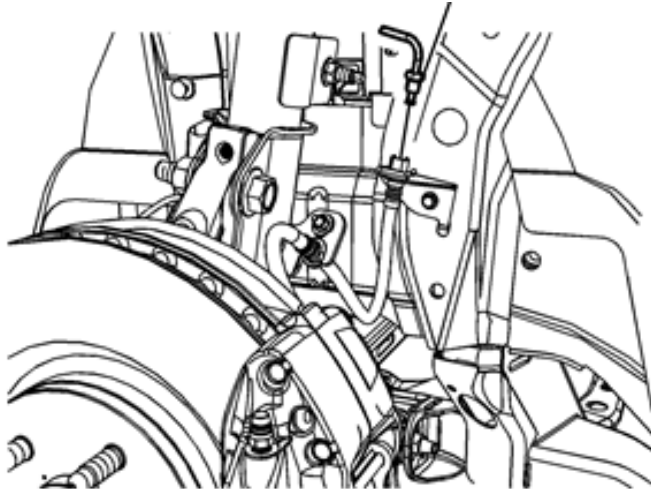

Séparer le raccord de conduite de frein (1) du flexible de frein

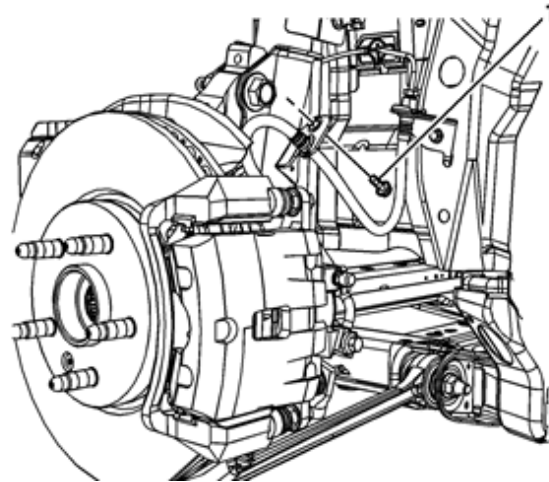

Déposer le boulon (1) de support de flexible de frein de la jambe de suspension.

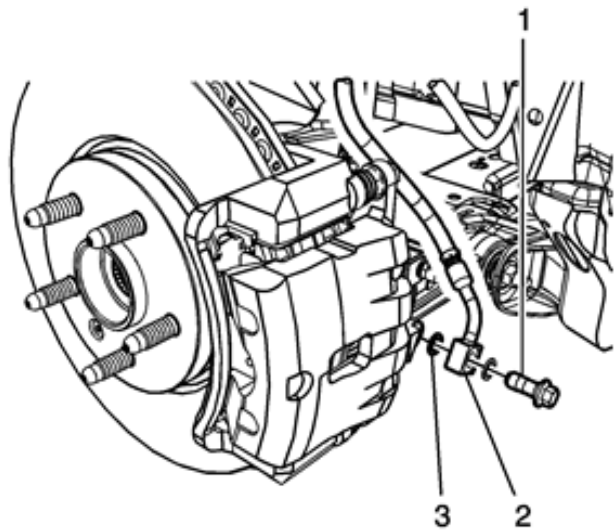

Enlever le boulon de flexible de l'étrier, puis jeter les rondelles. Déposer l'étrier du joint d'articulation.

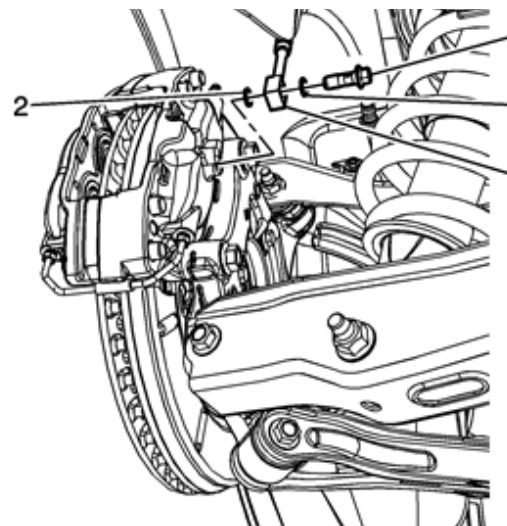

Modèles V6

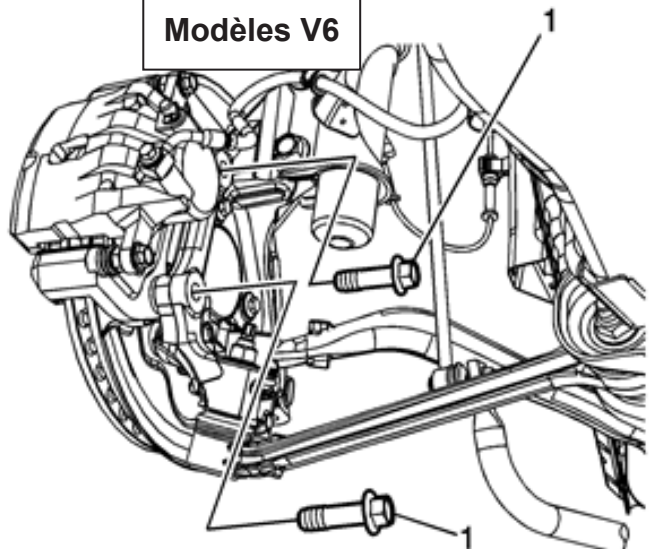

Modèles V8SS

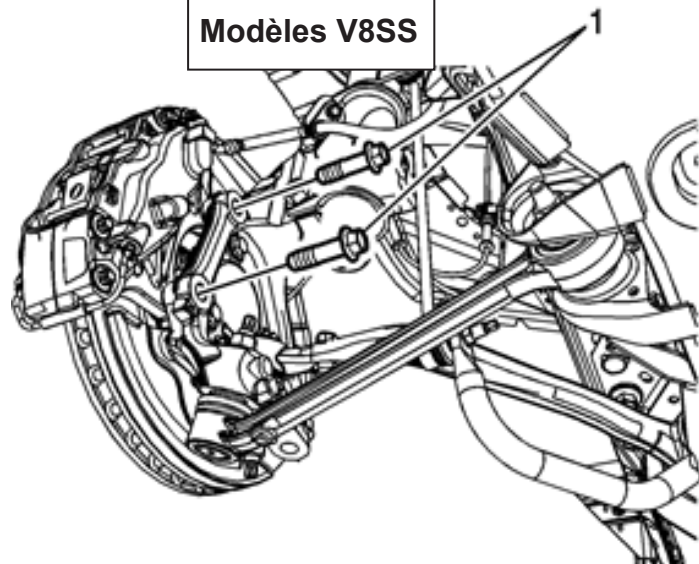

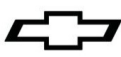

Déposer le disque de frein.

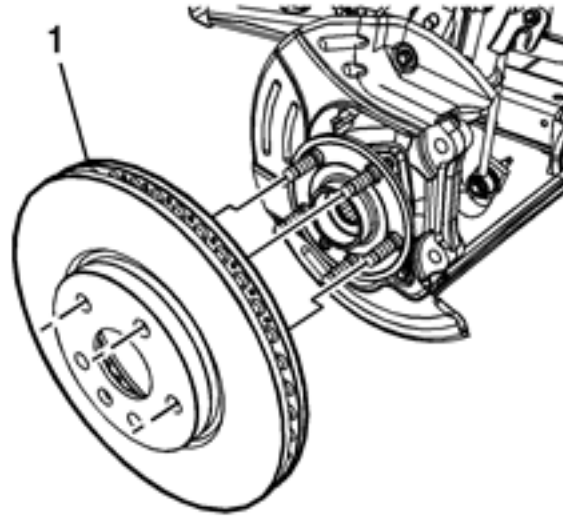
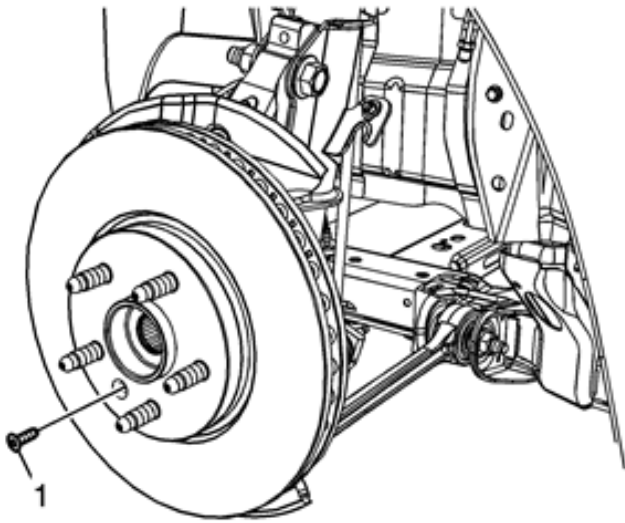

Déposer la tôle de protection.

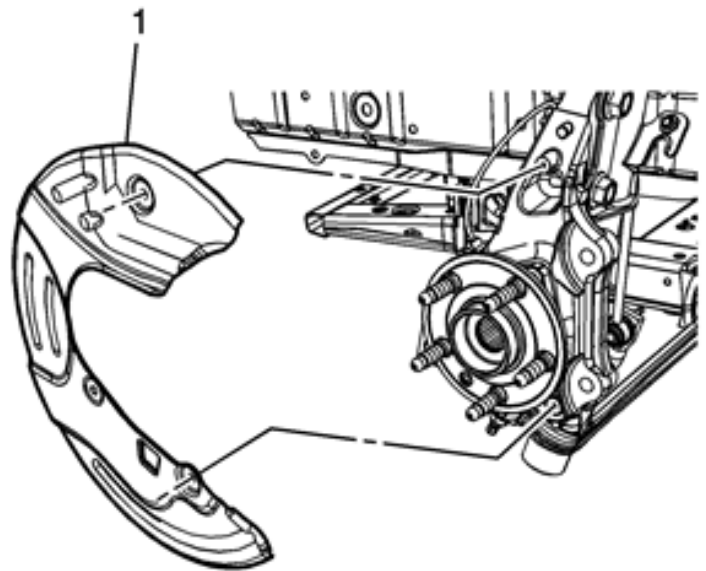
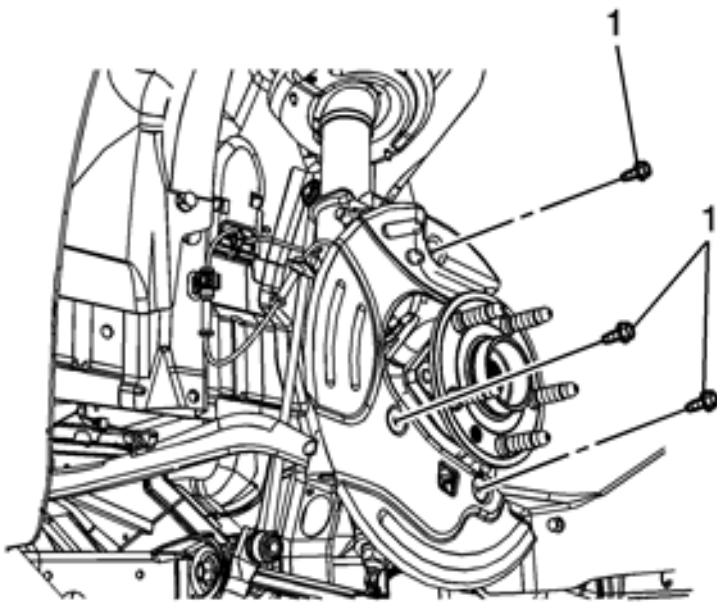

PROCÉDURE D'INSTALLATION

Poser la tôle de protection avant ZL.

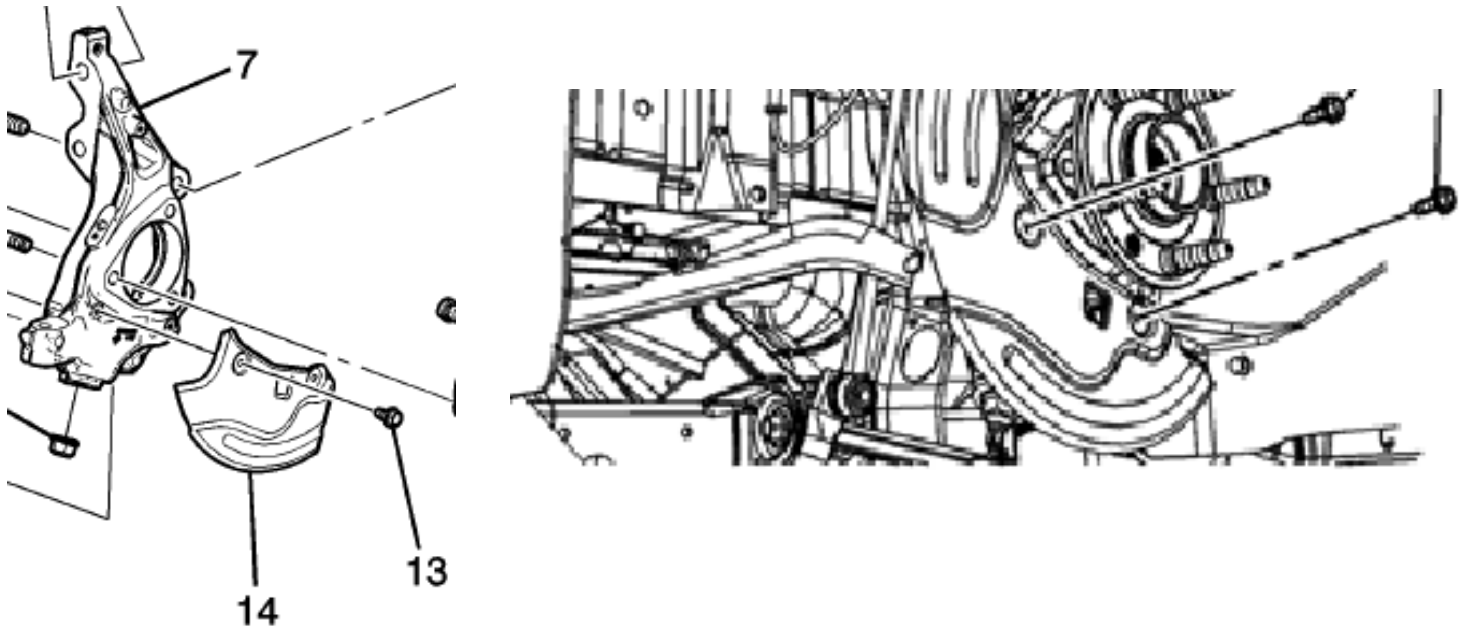

Poser les boulons (13) de tôle de protection de frein avant et serrer à **9 Nm (80 lb po)**.
Utiliser 2 des 3 boulons obtenus lors de la dépose.

Poser les disques de frein avant

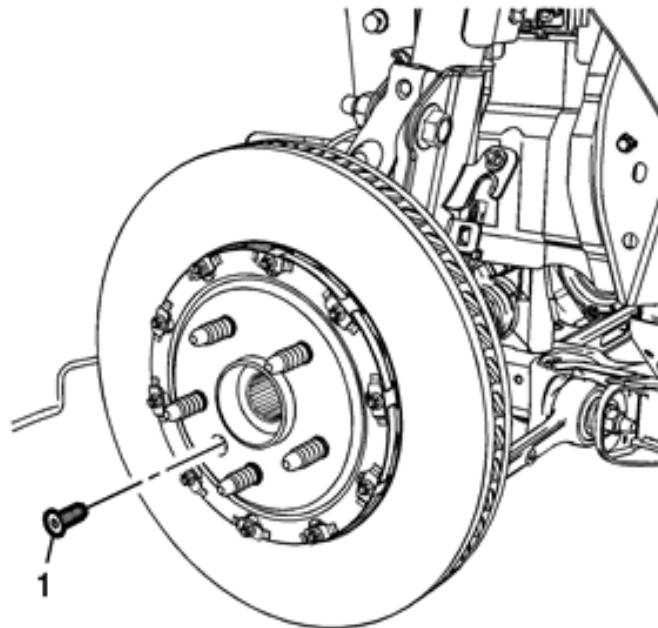

Poser la vis (1) de disque de frein et serrer à **10 Nm (89 lb po)**.
Utiliser l'ancienne vis.

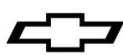

Poser l'étrier de frein ZL1.

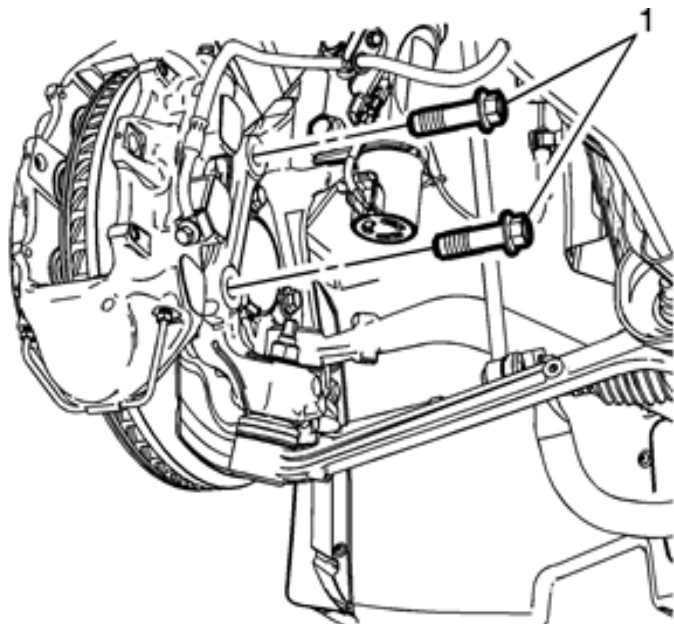

Remarque : Les boulons d'étrier de frein doivent être remplacés chaque fois qu'ils sont déposés.

Poser les nouveaux boulons (1) d'étrier de frein et serrer à **40 Nm (30 lb pi) + 90 degrés**.

Les boulons d'étrier sont fournis dans la trousse.

Poser les plaquettes d'étrier ZL1 et la trousse d'axe ZL1.

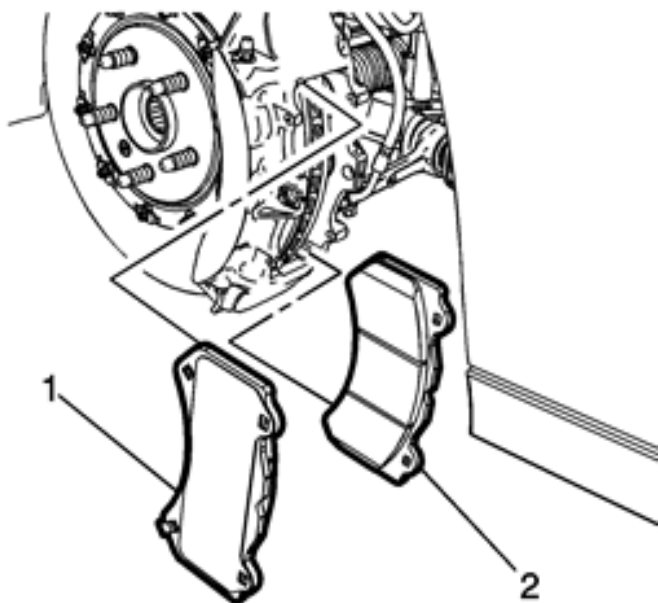

Remarque : Aligner le palpeur d'usure de plaquette de frein de la façon observée pendant la dépose.

Poser la plaquette de frein extérieure (1).

Poser la plaquette de frein intérieure (2).

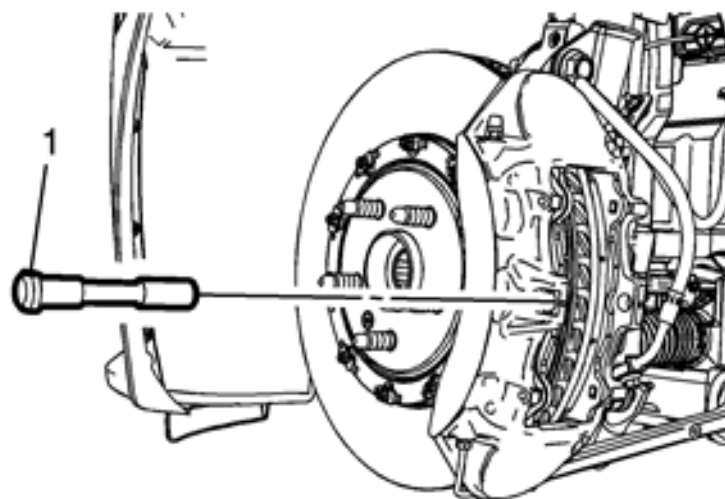

Poser l'axe-guide (1) d'étrier de frein.

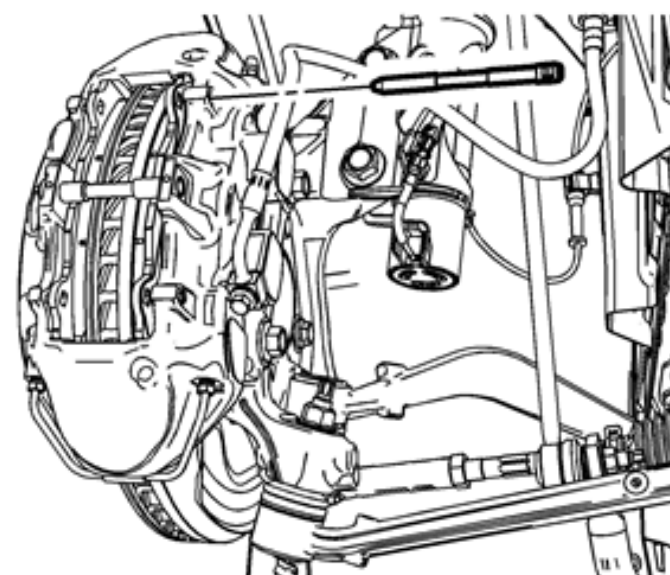
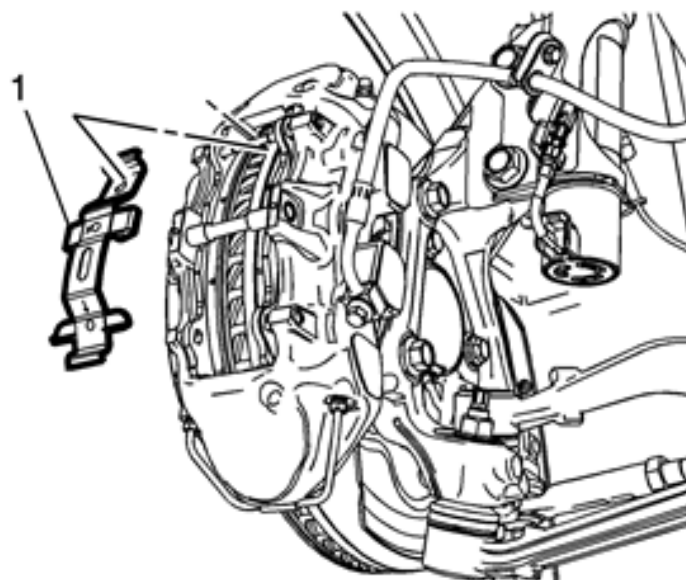

Poser l'axe de plaquette de frein supérieur (1).

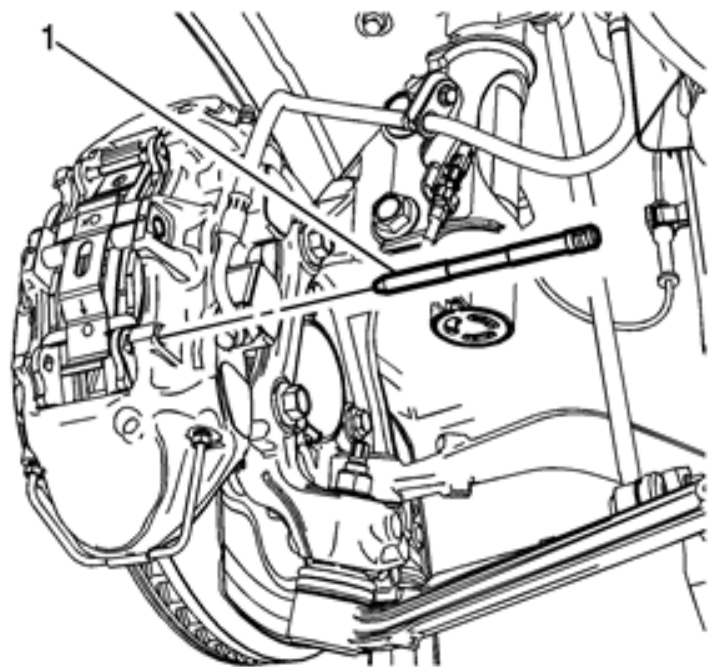

Poser l'axe de plaquette de frein inférieur (1).

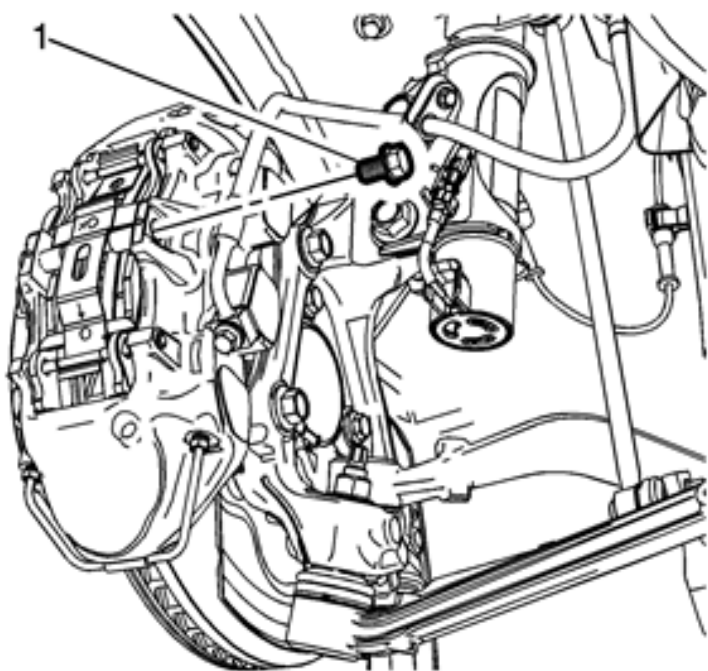

Poser le boulon (1) de l'axe-guide d'étrier de frein et serrer le boulon à **33 Nm (24 lb pi)**.

Poser le flexible de frein avant ZL1.

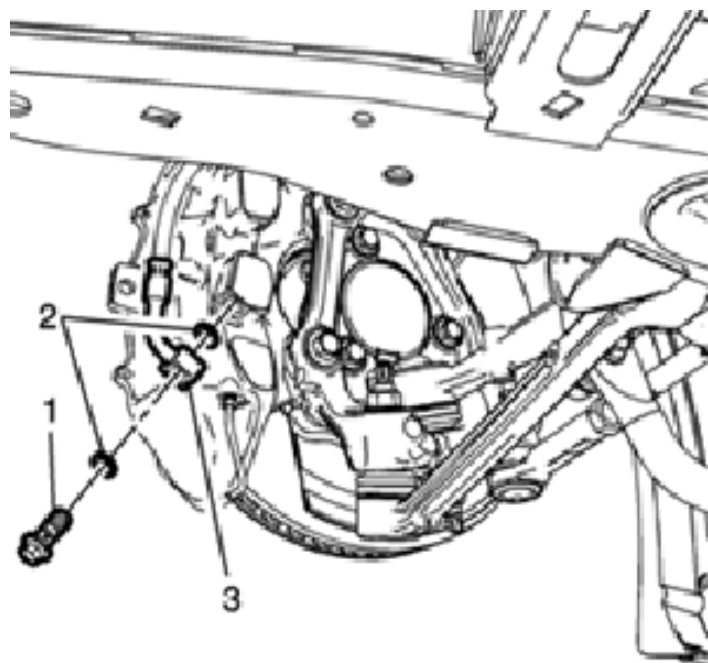

Assembler le boulon (1) de raccord de flexible de frein avec deux nouveaux joints (2) de raccord de flexible de frein sur le flexible de frein (3).

Poser l'ensemble flexible de frein sur l'étrier de frein et serrer le boulon de raccord de flexible de frein à **40 Nm (30 lb pi)**.

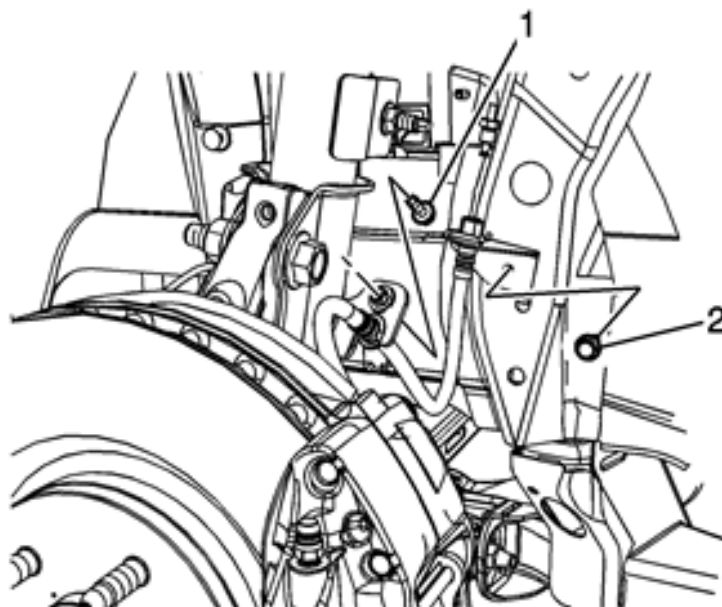

Raccorder le raccord (1) de conduite de frein et serrer à **16 Nm (12 lb pi)**.

Purger le circuit de frein hydraulique.
Poser l'ensemble roue et pneu.

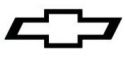

Brunissage

Le brunissage des plaquettes de frein et des disques de frein est nécessaire pour s'assurer que les surfaces de freinage sont correctement préparées après avoir effectué l'entretien du système de frein à disque.

Cette procédure doit être effectuée à chaque fois que les disques de frein sont rectifiés ou remplacés, et/ou à chaque fois que les plaquettes de frein sont remplacées.

1. Choisir une route lisse, avec peu ou pas de circulation.
2. Accélérer le véhicule jusqu'à 48 km/h (30 mph).

Remarque : veiller à éviter de surchauffer les freins en effectuant cette étape.

3. Avec une pression modérée à ferme, appliquer les freins pour arrêter le véhicule. Ne pas bloquer les freins.
4. Répéter les étapes 2 et 3 jusqu'à avoir effectué environ 20 arrêts. Laisser des périodes de refroidissement suffisantes entre les arrêts pour brunir correctement les plaquettes et les disques de frein.