



LS IGNITION CONTROLLER 19355418

Ignition Control for Carbureted LS Series Engines
(24x Crankshaft Index/1x Camshaft Index, 58x
Crankshaft Index/4x Camshaft Index)

<u>Parts Included</u>	<u>Quantity</u>
Ignition Controller	1
Main Harness	1
Sub Harness	1
Crank / Cam Pigtail 24x/1x	1
Crank / Cam Pigtail 58x/4x	1
USB Cable	1
Mounting Kit	1
MSDView USB Flash Drive	1

Optional Accessories (Not Included)

LS Coolant Temp Sensor, GM PN 12608814

WARNING: During installation, disconnect the battery cables. When disconnecting, always remove the Negative cable first and install it last.

Operation

The 19355418 LS Ignition Controller works with 24x/1x and 58x/4x crank/cam configurations. It auto detects the correct configuration based on the crankshaft retractor wheel pattern, so there is no need to select one. It provides six pre-programmed (non-editable) timing tables for stock engines, three customizable 3-D tables and one customizable timing plot. The desired table/plot is selected on the fly using the rotary dial. It provides a customizable timing plot that can be programmed via MSDView.

The LS Ignition controller includes a built-in 2.5 Bar Manifold Absolute Pressure (MAP) sensor that can be used with Naturally Aspirated or Forced Induction applications. This allows for timing advance or retard based on the intake manifold pressure.

8MB of internal data logging is also included to aid with tuning and vehicle performance analysis.

Software Installation

It is recommended, that you install and run MSDView software while connected to the unit to perform the base settings. The unit can be powered via the USB cable, so this can be done from a desktop or laptop and does not require an external power source.

Mounting

The Controller is designed to be mounted under the hood or on the bulkhead (front of dash panel). Do not mount the unit near exhaust. Four vibration mounts are supplied to mount the unit. The unit is fully potted, but should not be immersed or subjected to direct spray from a power washer.

Find a suitable location, confirm that all of the wires reach their connections. Mark the mounting hole locations using the unit as a template. Drill the holes with a 3/16" bit.

Wiring

All of the wiring, except three wires, are routed into factory style connectors to ensure an easy installation. The wire descriptions are listed on the following charts.



WIRING FEATURES

BLACK	Ground. Connect to a ground source, such as the engine or battery negative.
RED	Connect to a 12 volt switched source or dedicated fused 30A 12 volt source.
PINK	Step Retard. When 12-volts are supplied, the Step Retard is activated.
BLUE	Two-Step. When 12-volts are supplied, the Launch Rev Limiter RPM value is active.
GRAY	Tach. Provides a 12-volt square wave signal.

CAM/CRANK SENSOR – 10 PIN

ORANGE/YELLOW	Pin-1	Crank Sensor Signal
BROWN/WHITE	Pin-2	Cam Signal
ORANGE	Pin-3	5 Volt Supply
PINK	Pin-4	12 Volt Supply
BROWN	Pin-6	Sensor Ground

ENGINE COOLANT TEMP SENSOR (ECT)

BLACK	Pin-1	Sensor Ground
YELLOW	Pin-2	Engine Coolant Signal

COIL CONNECTOR – EVEN CYLINDERS

BLACK	Pin-A	Engine Ground
RED/GREEN	Pin-B	Coil 2
BROWN/GREEN	Pin-C	Coil 4
	Pin-D	Not Used
BROWN	Pin-E	Sensor Ground
BLUE/WHITE	Pin-F	Coil 6
VIOLET/BLUE	Pin-G	Coil 8
PINK	Pin-H	12 Volt Supply

COIL CONNECTOR - ODD CYLINDERS

BLACK	Pin-A	Engine Ground
RED	Pin-B	Coil 7
GREEN	Pin-C	Coil 5
	Pin-D	Not Used
BROWN	Pin-E	Sensor Ground
LIGHT BLUE	Pin-F	Coil 3
VIOLET	Pin-G	Coil 1
PINK	Pin-H	12 Volt Supply



	PIN	FUNCTION	COLOR	
16-Pin Connector	A	ECT	BLACK	2-Pin Connector Connects to Engine Coolant Temp (ECT) Sensor
	B	Sensor Ground	BROWN	Connect to Passenger's Side Coil Connector. (Coils 2-4-6-8)
	C	Coil 2	RED/GREEN	
	D	Coil 4	BROWN/GREEN	
	E	Coil 6	BLUE/ WHITE	
	F	Coil 8	VIOLET/BLUE	
	G	12V Supply	PINK	
	H	Main 12V Supply	RED	Connect to Relay or dedicated fused 30A switch.
	J	Ground	BLACK	Connect to a ground source.
	K	12V Supply	PINK	Connect to Driver's Side Coil Connector. (Coils 1-3-5-7)
	L	Coil 7	RED	
	M	Coil 5	GREEN	
	N	Coil 3	LIGHT BLUE	
	P	Coil 1	VIOLET	
	R	Sensor Ground	BROWN	
S	ECT	YELLOW	2-Pin Connector Connects to ECT Sensor	

	PIN	FUNCTION	COLOR	
10-Pin Connector	A	12V Sensor Power	PINK	Connect to Cam/Crank Pigtail.
	B	Ground	BROWN	
	C	Cam	BROWN/WHITE	
	D	Crank	ORANGE/YELLOW	
	E	5V Sensor Power	ORANGE	
	F	Factory Use	BLACK	
	G	Not Used		
	H	Step Retard	PINK	Step Retard is Activated When 12V is Supplied
	J	Launch Rev Limiter*	BLUE	When 12V is Supplied, the Launch Rev Limiter RPM Value is Active. (*2- Step)
	K	Tach	GRAY	Tach Output

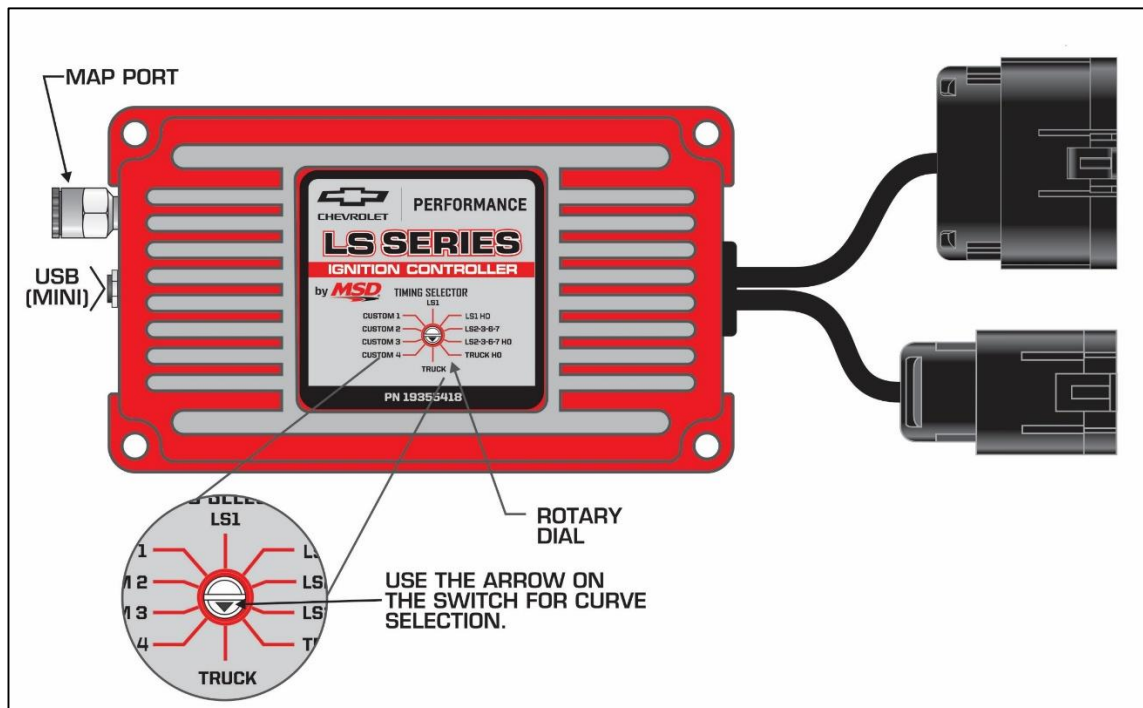

Figure 1 LS Ignition Controller PN1935418

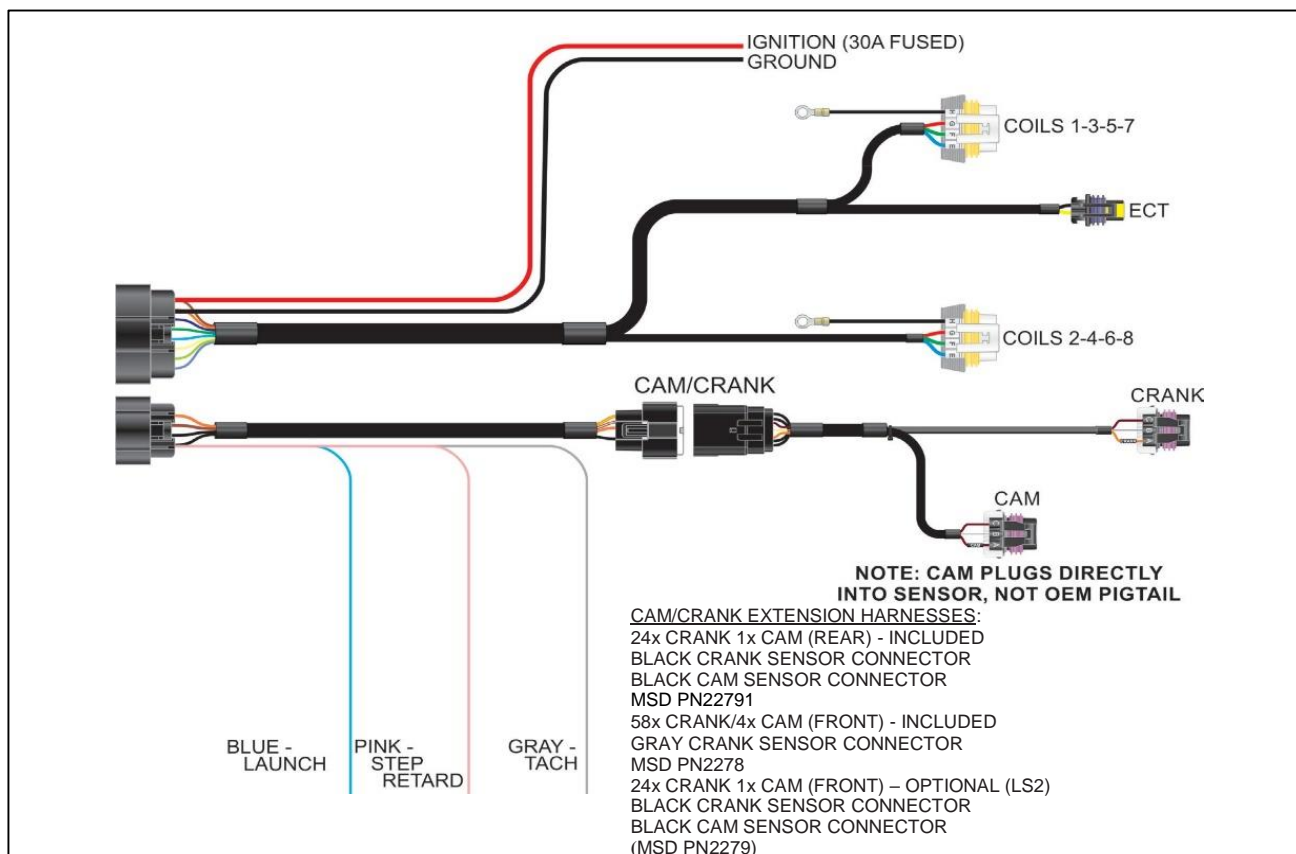

Figure 2 LS Ignition Harness

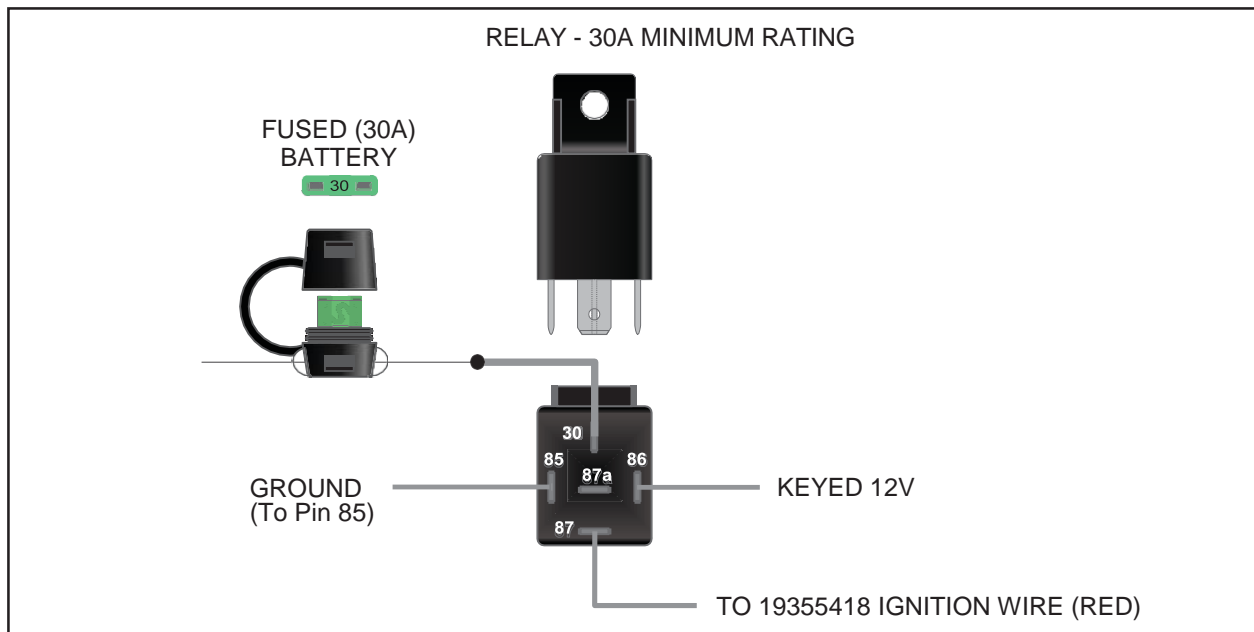

Figure 3 30A Relay/Fuse Diagram (Relay and Fuse Not Included)



MSDVIEW

The MSDView software allows editing of the first four timing tabs, as well as turning features on/off and setting up and retrieving data logs. The following information gives a brief explanation of each function or feature in the system and the settings that control them. While using the software, you can mouse over each item for a brief on-screen explanation.

Note: Make sure MSDView is installed on the PC prior to connecting the LS Ignition Controller.

PROGRAMMABLE FEATURES AND SETTINGS

These are basic settings that should be configured the first time the unit is used, but it is not required. A basic setup can be performed on the bench with just the USB cable connected to the device. No external power is required.

INSTALLATION OF THE MSDVIEW SOFTWARE

1. Insert the installation Flash Drive into an available USB port.
2. Locate the 'autorun.exe' file on the Flash Drive.
3. Click on "Install MSD View Software." Click 'Yes' when asked 'Do you want the following program to make changes to this computer?'
4. Click 'Next' in the 'Setup - MSD View' window. Accept the License Agreement and click 'Next'. Choose to accept the desktop icon then click 'Install'. Click 'Finish' to run the application.
5. Connect the LS Controller via USB and wait for it to be listed in the product window.

It will be listed in the product window. Select the LS Controller by highlighting the line or checking the box and clicking the 'View/Hide' button.

Note: The first time the unit is connected; it may prompt for updates to be installed.

Saves and Transfers

Changes made to the LS Ignition Controller via MSDView are in real time. You can create and save numerous different files to your PC and load them back into the unit for different applications. The following will go through a general description of the software for the LS Ignition Controller.

Optional Connections:

MAP Input: This is the Manifold Absolute Pressure sensor that is integral to the unit. It uses a 1/4" Camozzi fitting and is rated at 2.5 Bar. Using it can advance your timing under engine vacuum and retard it under boost. It is recommended that you use it, but not required unless you are using forced induction.

Coolant Temperature: This will monitor engine temperature. It has the ability to advance the timing while the engine is cold and retard it when it gets hot, helping to prevent engine damage. It is not required for the unit to function properly and leaving it disconnected will not advance or retard the timing relative to the base settings. The ECT Diagnostic will pop up, but will have no ill effect on the controller's functionality.

Programmable Features, Settings, and Data Acquisition:

These are basic settings that should be configured the first time the unit is used, but it is not required. A basic setup can be performed on the bench with just the USB cable connected to the device. No external power is required.

Maximum Rev Limiter: This is the maximum RPM that the engine can reach before the Rev limiter becomes active.

Coil Type: This selects the dwell or charge time of the coils. Choose "Auto" if unsure.

Auto- The controller will automatically match the coil dwell to the crankshaft reluctor wheel used.

LS-1 This sets the dwell time of the LS1/6 coils

LS2/3/7 This sets the dwell time of the LS2/3/7 coils

Truck This sets the dwell time of the early truck coils

Idle Timing Control

This will use timing to help stabilize the engine idle speed. It should be set to "ENABLED" on any engine that also used a computer controlled IAC. Enabling it will cause idle timing to be dynamic and it may appear to jump around at idle when using a timing light.

Timing Tables

Under this tab, you will find the timing tables used to control the spark output. The appropriate table is selected with the rotary dial on the front of the LS Ignition Controller. If connected with MSDView, you can double check this setting by looking at "Rotary Dial Position" under the monitor tab. The four "Custom" tables (Custom 1-4) are adjustable by the user while the other six cannot be modified. The cell values and axes (interval units) can be changed on all four of the Custom tables. For example, if more resolution is desired on the MAP axis in a Naturally Aspirated application, the interval units can be adjusted such that the maximum value does not exceed local atmospheric pressure. The axes on Custom tables 2-4 are linked, so changing one will change all of them. The Custom 1 axes are unique and can be changed independently of the Custom 2-4 axes.

Custom 1: This tab contains two sub tabs with plots that are similar to the GM PN 19171130 ignition controller. The “Engine Speed” tab is similar to springs and weights that would normally be found in a distributor. Set the base timing at your idle RPM and draw the advance curve as a normal distributor would. The “MAP” table represents a vacuum advance canister as well as a boost retard. Under a vacuum, it should advance the timing (positive values) and under boost it should retard values (negative numbers).

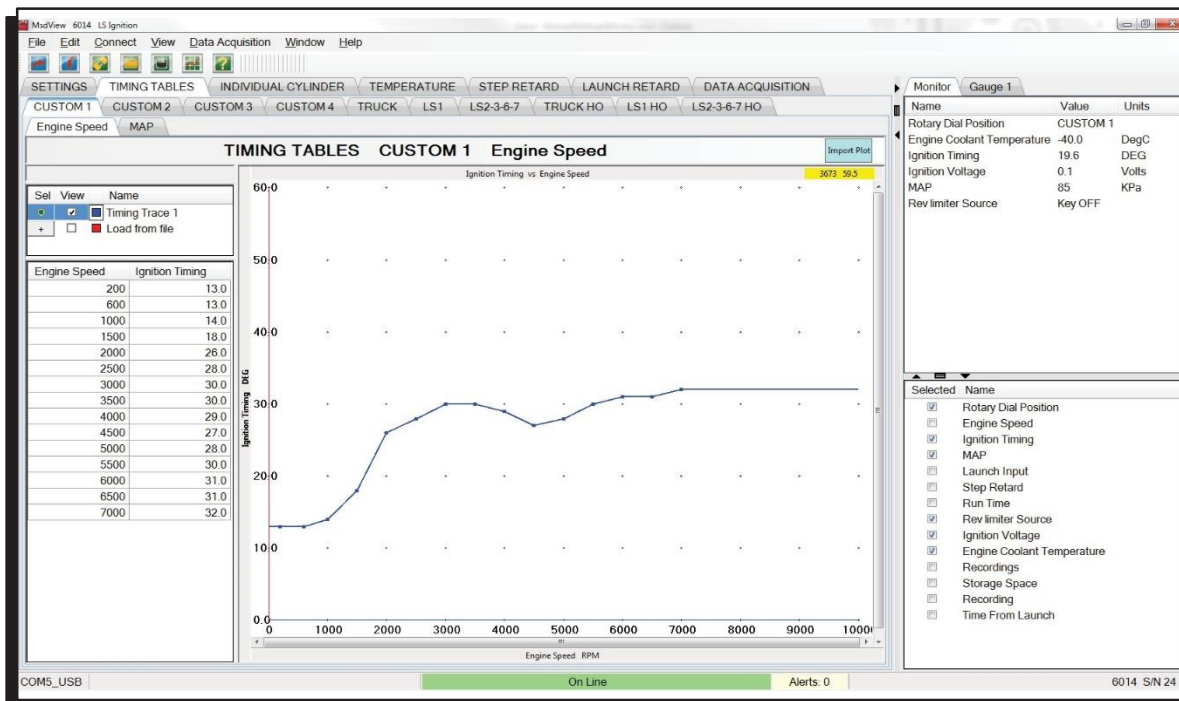

Figure 4 Custom Timing Table 1

Custom 2-4: These tabs are standard 3-D timing tables. The ignition timing will correspond to the value in the cell (the applicable cell being defined by RPM and engine load).



LS1: This tab is a timing table to be used on a LS1 with low octane fuel.

LS2-3-6-7: This tab is a timing table to be used on a LS2-3-6-7 or 6.2L truck motor with low octane fuel.

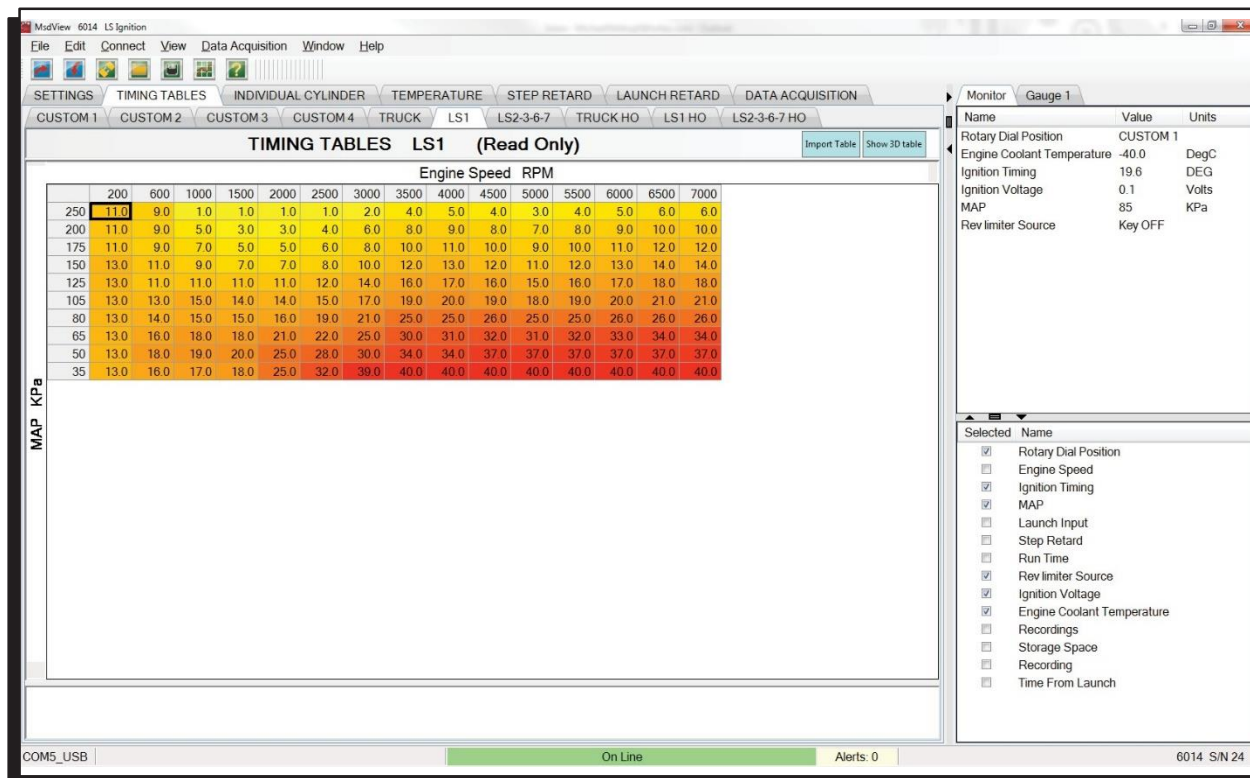

Figure 5 Timing Tables LS1

HO Tables: These tabs are similar to the regular tables, but have 4-5 more degrees of timing added in the wide open throttle areas. These should only be used while using high octane fuel (91-93 Octane).

Note: The timing output from the selected table will be modified by the “TEMPERATURE” correction as well as the “INDIVIDUAL CYLINDER” timing. The numerical sum of all these values corresponds to the actual timing value in degrees Before Top Dead Center (BTDC).

Individual Cylinder: These tables control individual cylinder timing. Each CYL # is the actual cylinder number of the engine. Positive values advance the timing and negative values retard the timing. The axes are load and RPM and are shared with the main custom timing tables (Custom 1-4). If the axis values are changed in these tables, they will also change in the custom timing tables.

Temperature: Running an engine coolant temp sensor is not required, but recommended for optimum operation and engine protection. When the coolant temperature is high, the engine can generally not withstand quite as much timing as when the coolant temperature is low. If the sensor is not installed or is faulted (shorted or open) the temperature in the graph will default to 50°C (122°F) so the numbers surrounding 122°F (50°C) should be left at zero (0).

Note: The Timing vs Temperature table values are based on the use of the stock LS GM coolant temp sensor. Do not use a different sensor unless you know the calibration is the same.

Step Retard (Pink Wire): The “Step Retard” (nitrous) input, will retard the ignition timing when it is activated with +12V power. It is helpful if you are using a power adder and need to retard the timing while it is active. The following describes how the activation/deactivation works:

Total Retard: The maximum amount of timing that will be removed after the “ON Ramp Time” has been passed.

Minimum Engine Speed: This is the minimum engine speed that must be met to retard the timing. If the “Step Retard” wire is activated below this RPM, it will have no effect and will not retard the timing. Set this at 0 (zero) if you want the step retard to be active regardless of engine RPM.

On Ramp Time: The time that it will take to reach the full “Total Retard”. This will allow for a softer timing retard over time. For example, if you have 10 degrees of Total Retard and a 1 second ramp time, the controller will retard 1 degree every 0.1 seconds until the full 10 degrees of timing has been pulled out. This timer will not begin until the “Minimum Engine Speed” is met. Setting On Ramp Time to 0 (zero) will cause an immediate timing retard corresponding to the Total Retard.

Off Delay: The time the Total Retard remains in effect after the “Step Retard” is deactivated. This can ensure that the intake manifold is void of residual nitrous. This will also delay the “Off Ramp Time” from starting - meaning that it is additive with respect to the Off Ramp Time.

Off Ramp Time: This will decay the effect of the Total Retard - effectively ramping timing back into the motor instead of adding it back instantaneously. Timing will start ramping back in after the “Off Delay” has expired.

Launch Retard: The Launch Retard is used to set the ignition timing during the 10 seconds after the launch wire is released. It can be helpful in optimizing traction immediately after launch. The Time From Launch is a monitor item and it is used by the LAUNCH RETARD table:

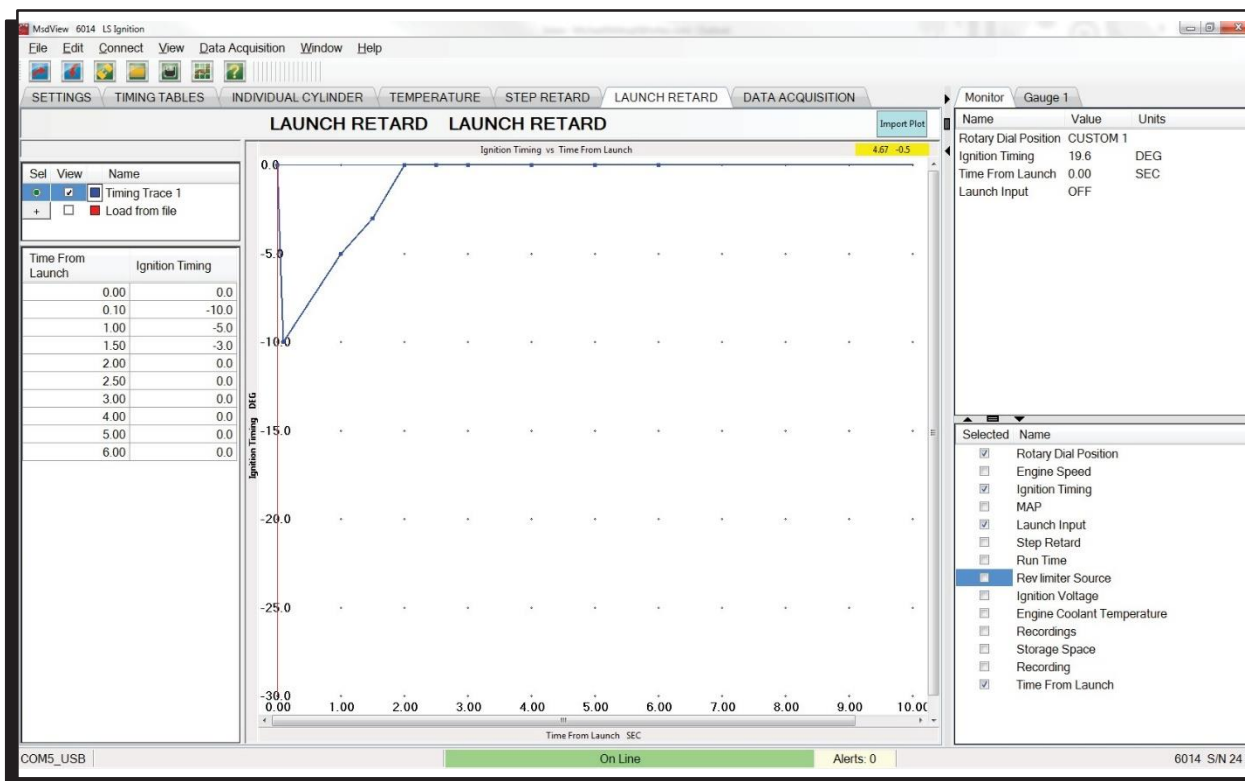

Figure 6 Launch Retard.



Data Acquisition: The data recorder on the LS Ignition system is a programmable 8MB storage system. It is meant to be a recording device to observe RPM, timing, input activations and a number of other different parameters during operation. Once the memory is full, the system will stop recording data until the user deletes some of the recordings.

Settings:

Data Acquisition: Master Enable/Disable switch.

Start Recording Above: The engine speed must be greater than this to begin recording.

Activate With Launch Input: If this is enabled, recordings will not start unless the "Launch" wire is activated. If it is disabled, recordings can start whenever the RPM conditions are met.

Stop Recording Below: If the engine speed falls below this, the recording will stop.

Max Recording Time: This is the longest any single recording can be. If the time is expired and all other conditions are still met a new recording will automatically begin.

Channels

Channel	DESCRIPTIONS
ENGINE SPEED	Engine speed in RPM.
IGNITION TIMING	Ignition timing referenced to degrees Before Top Dead Center (BTDC).
MAP	The Intake Manifold Absolute Pressure in kPa or PSIA.
Launch	Launch wire: activated = 1; not activated = 0.
Step Retard	Step Retard wire: activated = 1; not activated = 0.
ECT	Engine Coolant Temperature. It will show -40°F (-40°C) if not connected, but the controller will default it to 122°F (50°C) in the temperature timing control table.
Ignition Voltage	The voltage being supplied to the unit and the coils. It is important that it remains over 12V to ensure proper operation.
MAP Fault	Indicates the MAP sensor is open or shorted.
Battery Fault	Activates if voltage drops below 9V or goes above 18V.
CAM Fault	Indicates a problem with the camshaft position sensor (CMP). It will activate if RPM is detected but no cam sensor signal is detected.
Crank Fault	Indicates a camshaft sensor (CMP) signal is detected, but no engine speed is detected - likely resulting from a Crankshaft Position Sensor (CKP) fault.

Note: The system has a limit of 10 minutes of recording every time the Data Acquisition is enabled; that includes the initial enable at power up. After the limit is reached, the user must disable and re-enable the Data Acquisition in order for the system to continue recording.



Monitors

MONITORS	DESCRIPTIONS
ROTARY DIAL POSITION	Indicates which timing table is selected.
ENGINE SPEED	Engine speed in RPM.
IGNITION TIMING	Ignition timing referenced to degrees Before Top Dead Center (BTDC).
MAP	The Intake Manifold Absolute Pressure in kPa or PSIA.
LAUNCH INPUT	Launch Wire (blue) status (active or inactive).
STEP RETARD INPUT	Step Retard (nitrous) status (active or inactive).
RUN TIME	The length of time the engine has been running (resets with every power on cycle).
REV LIMIT SOURCE	Indicates which source will be limiting the motor. It will be Key Off when connected via USB, Launch when the launch wire is activated or Maximum any other time.
IGNITION VOLTAGE	This is the voltage being supplied to the unit. This is also the voltage being supplied to the coils - so it is important that it remains over 12V for optimum engine performance.
ENGINE COOLANT TEMP.	This is the engine coolant temperature in Celsius or Fahrenheit. It will display -40°F (40°C) if the sensor is not connected or open and 266°F (130°C) if it is shorted.
RECORDINGS	Number of recordings stored on the device.
STORAGE SPACE	Amount of free storage space for the recordings.
RECORDING	Indicates if the unit is currently recording a data file.
ROTARY DIAL SELECT	Indicates which timing table is selected with the rotary dial and will be used for timing control.
TIME FROM LAUNCH	Indicates the length of time since the Launch Input was de-activated. Used for Launch Retard.

Alerts

FAULTS	Descriptions/Causes
MAP SENSOR FAULT	MAP sensor problem (open or shorted).
BATTERY	Activates if voltage drops below 9V or goes above 18V.
ECT SENSOR	Displays -40°F (-40°C) if temp sensor is not connected; the controller will default it to 122°F (50°C) in the temperature timing control table.
CAM FAULT	RPM is detected but no cam sensor signal is present.
CRANK FAULT	Camshaft sensor signal is present, but no engine speed is detected.
EEPROM READ ERROR	EEPROM data corrupted.
EEPROM WRITE ERROR	Error writing to EEPROM.
FLASH READ ERROR	Flash data corrupted.
FLASH WRITE ERROR	Error writing to flash.
FLASH FULL	The flash is out of memory. Data acquisition is stopped. The user needs to delete recordings
DATA ACQUISITION	The data acquisition is almost full.
BUFFER WARNING	
AND DATA ACQUISITION	The data acquisition is full.
BUFFER FULL	

